



EE6510-10

BE18000 Wi-Fi 7 10G Ethernet Gateway

The Zyxel EE6510-10 BE18000 Wi-Fi 7 10G Ethernet Gateway leverages wireless 802.11be technology for optimized bandwidth utilization and increased network capacity. With ultra-fast connectivity, users experience improved performance and low latency. Equipped with dual 10G internet ports, the EE6510-10 provides flexibility and seamless wireless experiences, all within a compact footprint.

Benefits

The latest Wi-Fi 7 (11be) technology for wider multi-directional connectivity

The EE6510-10 boasts Wi-Fi 7 support for blazing tri-band speeds. Advanced features like OFDMA, MU-MIMO, and beamforming ensure lag-free streaming. Multi-Link Operation (MLO) enhances reliability and speed by aggregating bands. Leveraging 6 GHz channels and 4096-QAM, it maximizes throughput by 20% compared to Wi-Fi 6. Multi-RU Puncturing (MRU) optimizes data transmission with intelligent spectrum allocation.



Wi-Fi 7 (11be) tri-band 3x3 + 4x4 + 4x4 for superior performance and coverage



MLO (Multi-Link Operation) optimizes reliability and maximizes data speed



Zyxel MPro Mesh Solutions (Compliant with EasyMesh Standards)



Multiple SSIDs for various service deployment scenarios



Remote management via TR-369/TR-069/TR-181



Zyxel-developed OPAL for superior flexibility and faster time to market



With two 10G Ethernet ports, the wired speeds and multi-gigabit backhaul speeds

Premium MPro Mesh for whole-home Wi-Fi coverage

Featuring EasyMesh fully compliant Zyxel MPro Mesh Solutions, the EE6510-10 enhances the user's experience by providing your subscribers superior Wi-Fi experiences with an easy-to-setup, intuitive mobile app on all devices anywhere, anytime.

Zyxel OPAL firmware achieves superior flexibility and shortens time to market

Compliant with the Zyxel CPE OPAL firmware trunk, and applying to the EE6510-10, existence wealthy OPAL technology and field-proven feature collection for guaranteed the same user experience after migrating to new devices.

Remote management for lower OPEX

Built-in TR-369/TR-069/TR-181 protocols greatly reduce your service expenses while enhancing customer satisfaction with fewer truck rolls and better OPEX.

Dedicated 10GbE WAN and LAN port for Multi-Gig internet access

The EE6510-10 boasts blazing speeds with its one 10GbE WAN port, one 10GbE LAN port, and three 1GbE LAN ports, ensuring high-performance connectivity for your network. Additionally, its multi-gigabit backhaul speeds further enhance its speed and reliability.

Specifications

System specifications

Wireless standards

- IEEE 802.11 b/g/n/ax/be 2.4 GHz
- IEEE 802.11 a/n/ac/ax/be 5 GHz
- IEEE 802.11 ax/be 6 GHz

Wireless transfer rates

- Transmit:
 - 802.11be (2.4 GHz): up to 1032 Mbps
 - 802.11be (5 GHz): up to 5764 Mbps
 - 802.11be (6 GHz): up to 11528 Mbps

Wireless features

- Auto channel selection
- WMM
- WPA2-PSK
- WPA3-SAE
- Wireless output power management
- Multiple SSID up to 4 for each band
- Wi-Fi Protected Setup (WPS)
- Intra-BSS traffic block
- MAC address filtering
- WPS 2.0
- MPro Mesh

Firewall

- IPv4/IPv6 firewall (Stateful Packet Inspection)
- Denial-of-Service (DoS) attack prevention
- ICMP blocking

Routing

- IPv4/IPv6
- NAT
- Port forwarding
- WAN connection type: DHCP, PPPoE
- DHCP option 60/121/125
- DHCP server on LAN
- IGMP v2/v3
- IGMP proxy
- Dynamic DNS
- QoS support

VLAN

- 802.1q tag/tag based VLAN
- VLAN to ETH port mapping
- Bridged/routed VLAN support

Management

- Web GUI (HTTPS)
- TR-369/TR-069/TR-181
- Firmware upgrade through GUI/TR-069
- 2-tier level access and administration
- CAF II TR143 speed test support

Hardware specifications

WAN

- One 1/2.5/10 GbE RJ-45 port

LAN

- One 1/2.5/10 GbE RJ-45 port
- Three 1GbE RJ-45 ports

Wireless

- 2.4 GHz: 3x3 internal antenna
- 5 GHz: 4x4 internal antenna
- 6 GHz: 4x4 internal antenna

USB

- One USB 3.0 host

LEDs indicators

- Power
- Internet
- Wi-Fi
- WPS

Button

- WPS
- Reset

Power consumption

- 12 V DC/3.5 A
- 42 Watt max

Physical specifications

- Item dimensions (WxDxH): 180.5 x 74.0 x 231.5 mm (7.11" x 2.91" x 9.11")
- Item weight: 1003 g (2.21 lb.)
- Packing dimensions (WxDxH): 267 x 236 x 95 mm (10.51" x 9.29" x 3.74")
- Packing weight: 1550 g (3.42 lb.)

Environmental specifications

Operating environment

- Temperature: 0°C to 40°C (32°F to 104°F)
- Humidity: 10% to 90% (Non-condensing)

Storage environment

- Temperature: -30°C to 70°C (-22°F to 158°F)
- Humidity: 10% to 95% (Non-condensing)

Certification

- FCC
- IC

Package contents

- Ethernet gateway
- Power adapter
- Ethernet cable
- Quick Start Guide

* The maximum wireless data transfer rate is derived from IEEE Standard 802.11 specifications. Actual data transfer rate will vary from network environment including distance, network traffic, building site materials/construction, interference from other wireless devices, and other adverse conditions.

Application diagram

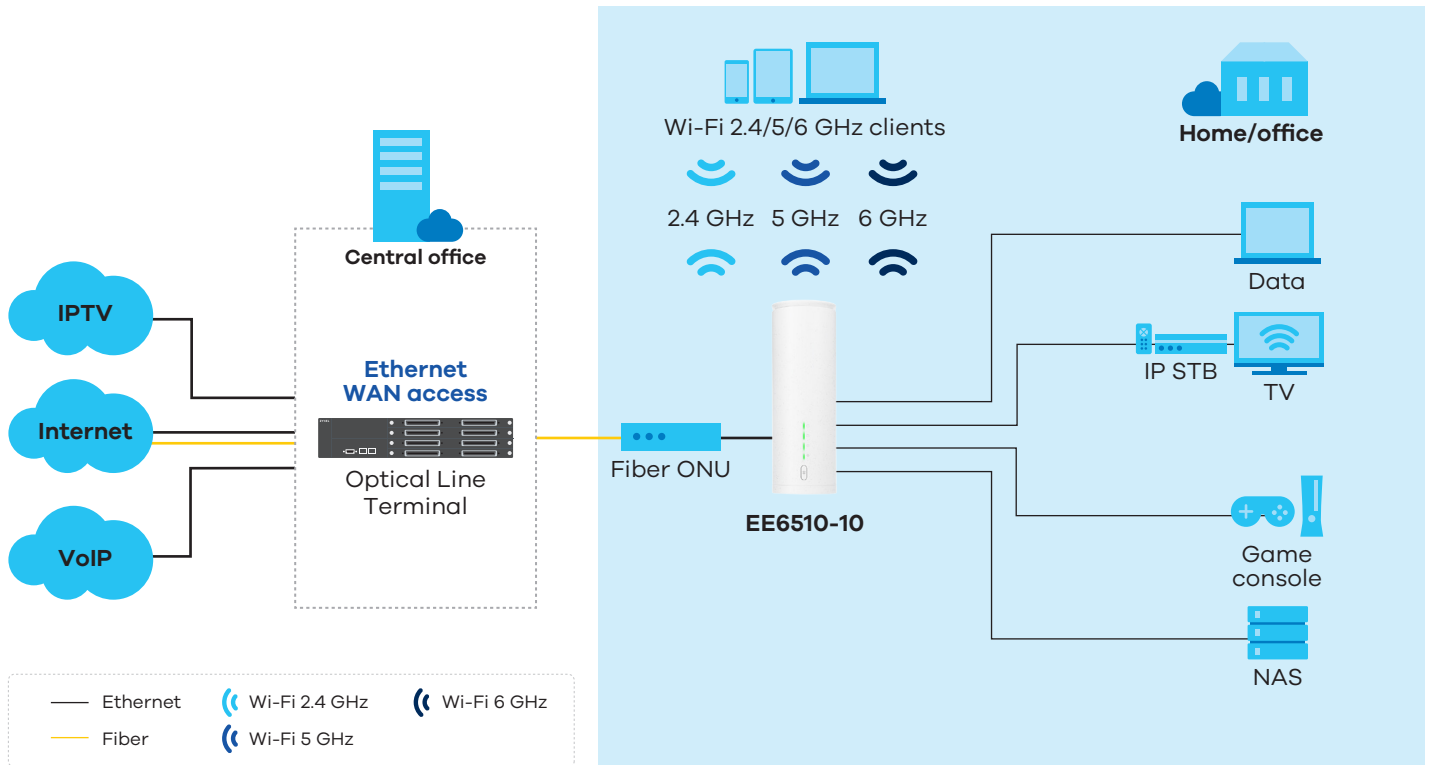

Hardware interface

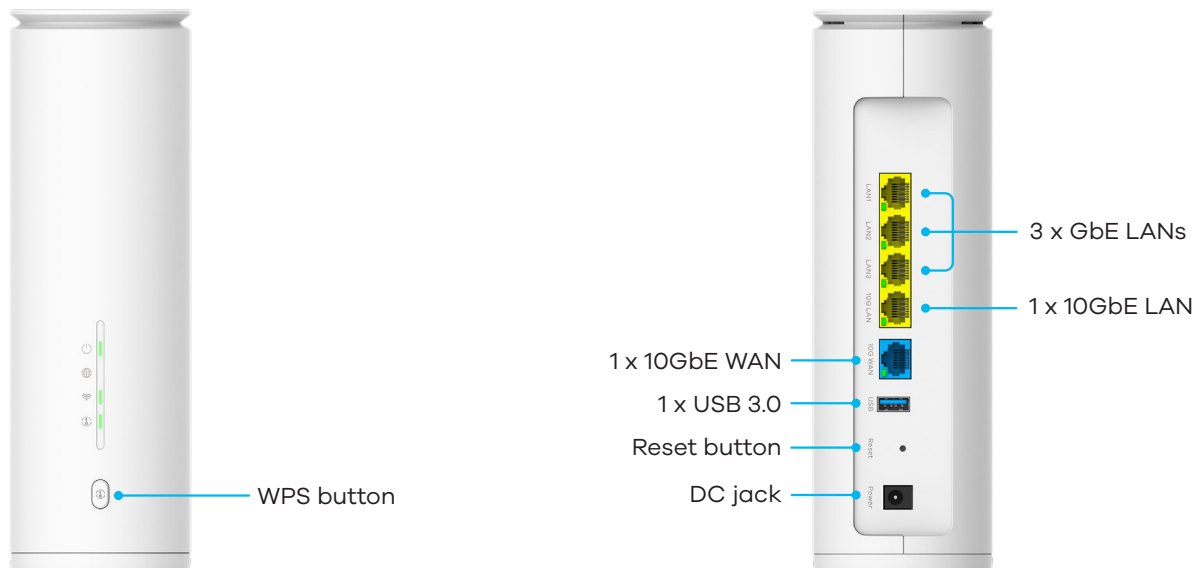

For more product information, visit us on the web at <https://www.zyxel.com/service-provider>

Copyright © 2024 Zyxel and/or its affiliates. All rights reserved. All specifications are subject to change without notice.



26/04/24